

MES1813P

DC/DC Converter

General Description

MES1813P is a DC-to-DC converter which can be used to supply DC output from a commercial power supply (85 to 265 VAC). Using these module enable simple, easy drive of microcomputers, LEDs, and other electronic components without using a transformer.

It also allows set PCBs to be kept compact and lightweight, with extremely few attachments. It can accommodate the 100VAC~265VAC power supplies used as household power supplies.

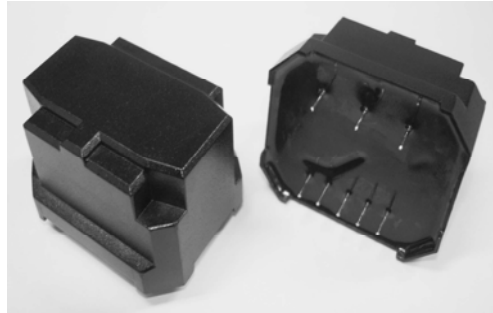

Application

- Small multi-purpose power supply.
- Stand-by power supply aimed at low power consumption when loaded light.
- Insulated-type DC-DC converted.

Features

- Wide Input Range : FREEVOLT (AC 85V ~ 265V)
- A switching power supply can be made easily by adding simply external circuit
- Permits reduction of power consumption at low loads(when in stand-by)
- Able to deal with inputs of worldwide areas
- Ultra-compact size attained by application of high-density mounting technique
- Application of the unique molding technique features
 - Compliance with various safety regulations from the compact size
 - Humming is prevented when intermittent oscillation
- Over Temperature Protection
- Output Short Circuit Protection
- Over Load Protection

Absolute Maximum Ratings (Ta = 25°C)

Characteristics	Symbol	Rating	Unit
Input Voltage	V _{IN}	120 ~ 375	V _{DC}
Output Voltage	V _{OUT}	18	V
Maximum Output Current	I _{OMAX}	1.3	A
ESD Endurance	V _{SURGE}	2	kV
Maximum Surface Temperature	T _{CMAX}	105	°C
Ambient Operating Temperature Range	T _{OPR}	-10 ~ +60	°C

MES-Series DC to DC Converter Modules

Storage Temperature Range	T _{STG}	-40 ~ +105	°C
---------------------------	------------------	------------	----

Pin Assignment

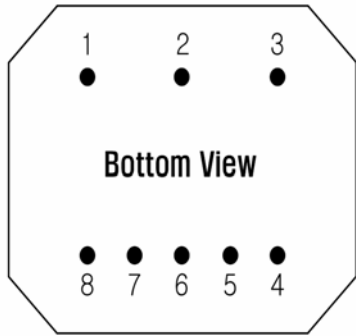

Block Diagram

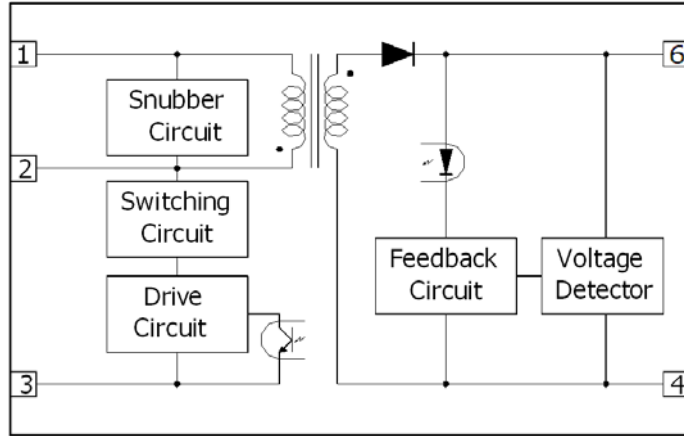

Pin Descriptions

Pin Name	Pin No.	I/O	Description
+DC IN	1	I	DC Input Terminal, DC 120~375V
DRAIN	2	O	Drain Output Terminal, Note1
- DC IN	3	I	DC Input Terminal, Input Ground
- DC1 OUT	4	O	DC1 Output Terminal, Output Ground
NC	5		No Connection, Note1
+DC1 OUT	6	O	DC1 Output Terminal, 18V
NC	7		No Connection, Note1
NC	8		No Connection, Note1

(Note1) Refer to the application circuit over pin connection

Electrical Characteristics

Characteristics	Symbol	Condition	Min.	Typ.	Max.	Unit
Input Voltage Range	V _{IN}		120	311	375	V _{DC}
Output Voltage	V _O	V _i =311V, I _o =1.3A	17.5	18.0	18.5	V
Output Current	I _O	V _i =311V	-	-	1.3	A
Line Regulation	V _R	V _i =120~375V, I _o =1.3A	-0.10	0.05	0.10	V
Load Regulation	V _L	V _i =311V, I _o =0~1.3A	-0.15	0.05	0.15	V
Output Ripple Voltage	V _P	V _i =311V, I _o =1.3A	-	0.05	0.10	V _{p-p}
Power Conversion Efficiency	η	V _i =311V, I _o =1.3A	68	75	-	%

Application Circuit

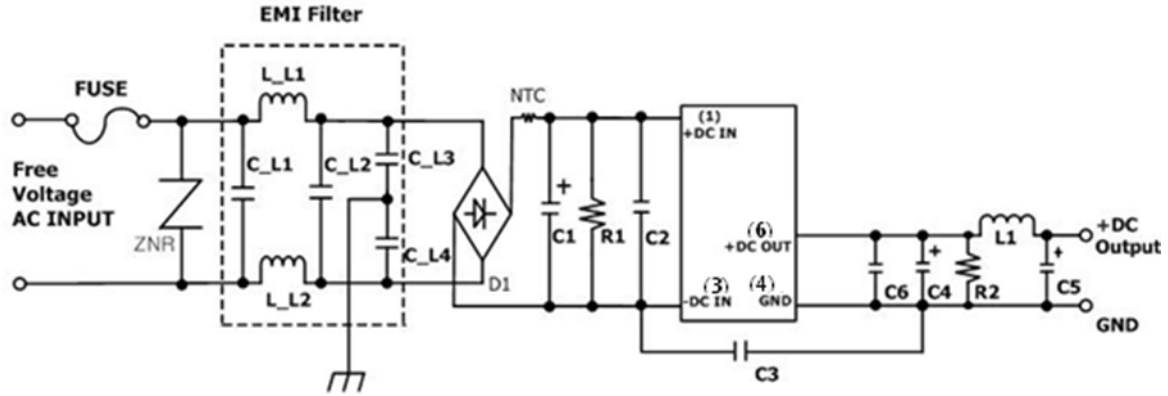

External Component Setting

FUSE	Fuse	Please make sure to use quick acting fuse 220V/2A or higher
C1	Capacitor for input voltage smoothing	Capacitance : 68 μ F~820 μ F, Rated voltage : 400V or higher Ripple current is 0.13Arms above.
C2	For noise terminal voltage reduction	Capacitance : 0.1 μ F~0.22 μ F, Rated voltage : 400V or higher Film capacitor or ceramic capacitor. Reduce the noise terminal voltage. The constant value should be evaluated in the set.
C3	Capacitor for Safety	Capacitance : 1nF~4.7nF, Rated voltage : 1KV or higher
C4,C5	Capacitor for output voltage smoothing	Capacitance : 680 μ F~3000 μ F, Rated voltage : 25V or higher ESD is 0.4 Ω max. Ripple current is 0.25Arms above. Output noise voltage is influenced. Please evaluate it in the actual set.
C6,C7	Capacitor for output voltage smoothing	Capacitance : 680 μ F~1000 μ F, Rated voltage : 25V or higher ESD is 0.4 Ω max. Ripple current is 0.25Arms above. Output noise voltage is influenced. Please evaluate it in the actual set.
C8,C9	Bypass Capacitor for high frequency noise	Capacitance : 10nF~100nF, Rated voltage : 50V or higher Film capacitor or ceramic capacitor. Reduce the high frequency noise terminal output.
L1,L2	Choke Coil	L : 4.7 μ H~10 μ H, Allowable current : 800mA or higher Please use the one that is hard to be magnetic saturated even in the high temperature.

R1	Discharge Resistor	500kΩ or higher , 1W or higher
D1	Rectifier Diode	In the absolute maximum ratings, the reverse peak voltage should be 500V or higher, the average rectifying current should be 2A or higher, and the peak surge current should be 10A or higher. (Full-wave rectifier can be used in out part.)
D2	Ultra Fast Recovery Diode	In the absolute maximum ratings, the reverse peak voltage should be 200V or higher, the average rectifying current should be 2A or higher, and the peak surge current should be 10A or higher. (Full-wave rectifier can be used in out part.)

Package Outline

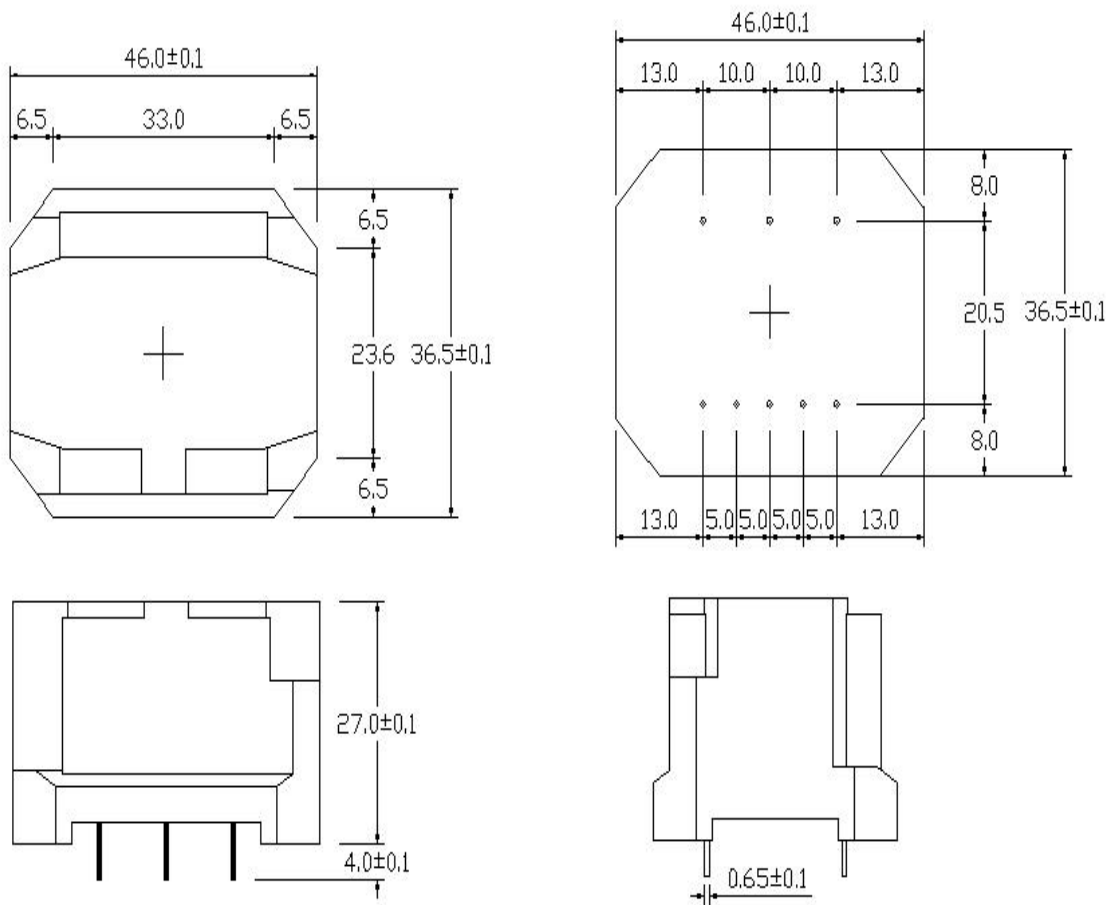

Ordering Information

MES-Series DC to DC Converter Modules

Order Number	Ambient Temperature Range	Package Type
MES1813P	-10°C ~ 60°C	

* Please consult the factory or sales representative for pricing and availability.

POWERGEN Co., Ltd.

67-13, Shinchon-dong, Changwon si, Gyeongnam, S.Korea, 642-370

TEL+82 55 275 7801 ~4 FAX +82 55 275 2522

This semiconductor technical data is believed to be accurate and reliable, however POWERGEN does not assume any responsibility arising out of the application or use of any product or circuit described herein; neither does it convey any license under its patent rights nor the rights of others.

POWERGEN reserves the right at anytime without notice to change said circuitry and specifications.