

HBPS03 SERIES AC - DC POWER SUPPLY

■ Special Features

- Small multi-purpose power supply
- Wide Input Range(85Vac~265Vac)
- Isolated output
- Short circSuit protection
- Over voltage protection
- Thermal shutdown
- Ultra compact size



■ Electrical Characteristics

Characteristics		Condition	Min.	Typ.	Max.	Unit
AC Input	Input Voltage Range	-	85	220	265	V
	Frequency	Vi=AC220V	47	-	440	Hz
	inrush current	Vi=AC220V	-	30	-	Apk
	Stand-by Power Consumption	Vi=AC220V	-	-	0.3	W
Output	Voltage set accuracy	Vi=AC220V, Io= Full load	-	±1	±2	%
	Line Regulation	Vi=AC85~265V, Io= Full load	-	±0.1	±0.5	%
	Load Regulation	Vi=AC220V, Io= Full load	-	±1.0	±1.5	%
	Ripple Voltage	Vi=AC220V, Io= Full load	-	-	150	mVp-p
	hold-up time	Vi=AC220V	80	-	-	ms
	switching frequency	Vi=AC220V, Io= Full load	-	130	-	KHz
	isolation voltage-	1 minute at 5mA	3000	-	-	Vac
Ambient Temperature	Operating Range	Vi=AC220V, Io= Full load	-20	-	80	°C
	Storage Range		-30	-	105	°C

■ **Model Guide**

Model	output voltage(Vdc)	output current(mA)	output power(W)	Efficiency (%)	Ripple and noise(mVp-p)
HBP0333	3.3	600	1.96	67	120
HBP0305	5	600	3	70	120
HBP0309	9	333	3	72	120
HBP0312	12	250	3	74	120
HBP0315	15	200	3	75	120
HBP0324	24	125	3	77	120

■ **Block Diagram**

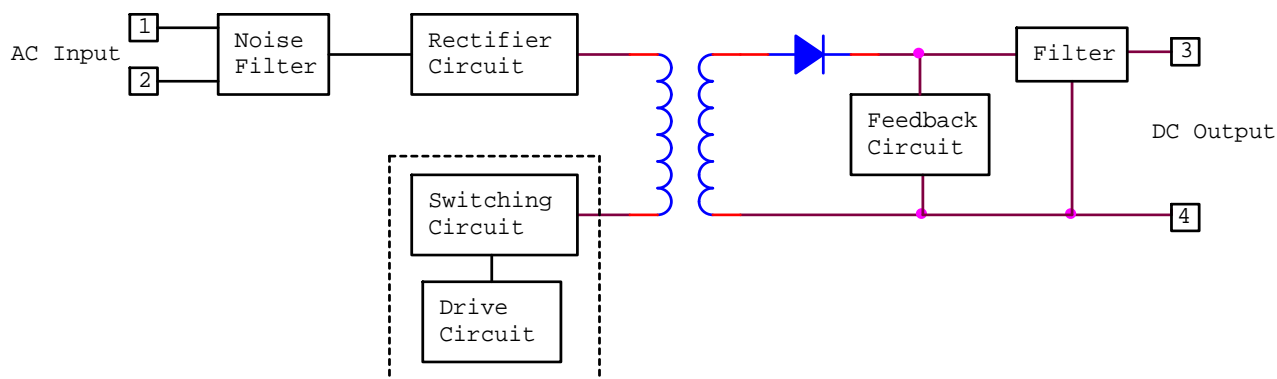

■ **Dimension**

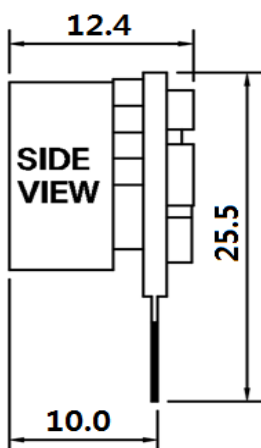
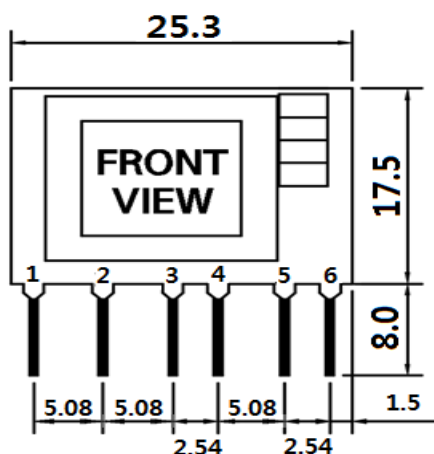

Pin No.	Description
1	AC(N)
2	AC(L)
3	+V(CAP)
4	-V(CAP)
5	GND
6	DC OUTPUT

Notes 1.Dimension in mm, 2. PIN : Ø 1.6

Application Circuit

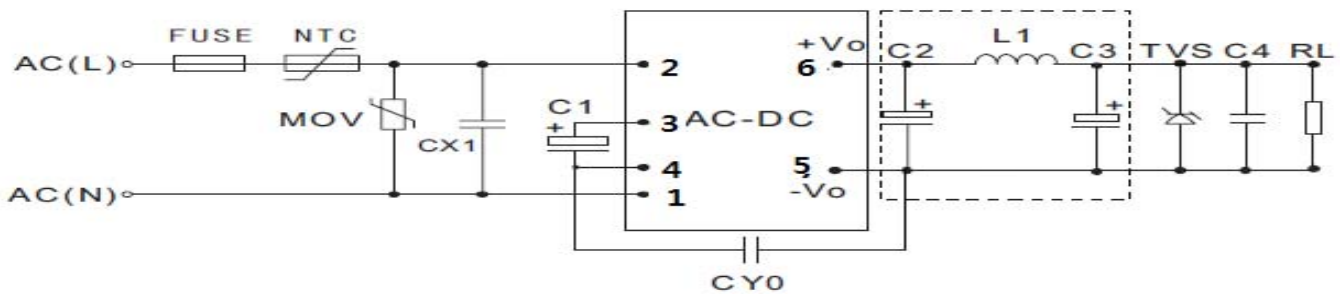

Recommended external circuit components											
V _{OUT} (Vdc)	C1 ¹	C2 ¹	L1 ¹	C3 ¹	C4	CX1	CY0	FUSE	NTC	MOV	TVS
3.3	22μF/400V	470μF/10V	0.47μH	150μF/35V	100nF/50V	0.1μF/275Vac	1nF/400Vac	1A/250V	5D-9	S14K350	SMBJ7.0A
5	22μF/400V	470μF/16V	0.47μH	150μF/35V	100nF/50V	0.1μF/275Vac	1nF/400Vac	1A/250V	5D-9	S14K350	SMBJ7.0A
9	22μF/400V	330μF/25V	1μH	150μF/35V	100nF/50V	0.1μF/275Vac	1nF/400Vac	1A/250V	5D-9	S14K350	SMBJ12A
12	22μF/400V	330μF/25V	1μH	150μF/35V	100nF/50V	0.1μF/275Vac	1nF/400Vac	1A/250V	5D-9	S14K350	SMBJ20A
15	22μF/400V	330μF/25V	1μH	150μF/35V	100nF/50V	0.1μF/275Vac	1nF/400Vac	1A/250V	5D-9	S14K350	SMBJ20A
24	22μF/400V	100μF/35V	4.7μH	47μF/35V	100nF/50V	0.1μF/275Vac	1nF/400Vac	1A/250V	5D-9	S14K350	SMBJ30A

FUSE	Fuse	Please make sure to use quick acting fuse 1A or higher
C1	Capacitor for input voltage smoothing	Capacitance : 33μF~820μF, Rated voltage : 400V or higher Ripple current is 0.13Arms above.
CX1	For noise terminal voltage reduction	Capacitance : 0.1μF~0.22μF, Rated voltage : 400V or higher Film capacitor or ceramic capacitor. Reduce the noise terminal voltage. The constant value should be evaluated in the set
C2, C3	Capacitor for Safety	Capacitance : 1nF~4.7nF, Rated voltage : 35V or higher
C4	Bypass Capacitor for high frequency noise	Capacitance : 10nF~100nF, Rated voltage : 50V or higher Film capacitor or ceramic capacitor. Reduce the high frequency noise terminal output
L1	Choke Coil	L : 4.7~10μH, Allowable current : 3A or higher Please use the one that is hard to be magnetic saturated even in the high temperature.

POWERGEN Co., Ltd.

67-13, Shinchon-dong, Changwon si, Gyeongnam, S.Korea, 642-370

TEL : +82 55 275 7801~4

FAX + : 82 55 275 2522

Homepage : www.pwrg.co.kr

Online shop : www.pwrgmall.co.kr

This semiconductor technical data is believed to be accurate and reliable, however POWERGEN does not assume any responsibility arising out of the application or use of any product or circuit described herein; neither does it convey any license under its patent rights nor the rights of others.

POWERGEN reserves the right at anytime without notice to change said circuitry and specifications.